

General Description

Series D*1FC pilot operated proportional directional valves come in 4 sizes:

- D31FC NG10 (CETOP 5)
- D41FC NG16 (CETOP 7)
- D91FC NG25 (CETOP 8)
- D111FC NG32 (CETOP 10)

The digital onboard electronics is situated in a robust metal housing, which allows usage under rough environmental conditions.

The nominal values are factory set. The cable connection to a serial RS-232 interface is available as an accessory.

The innovative integrated regenerative function into the A-line (optional) allows energy saving circuits for differential cylinders. The hybrid version can be switched between regenerative mode and standard mode at any time.

Features

- Progressive flow characteristics for precise adjustment of flow rate.
- Low hysteresis.
- High dynamics.
- High flow capacity.
- Center position monitoring optional.
- Energy saving A-regeneration optional.
- Switchable hybrid version optional.

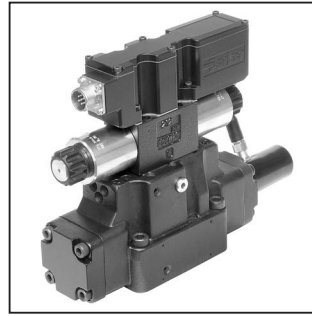

D41FC

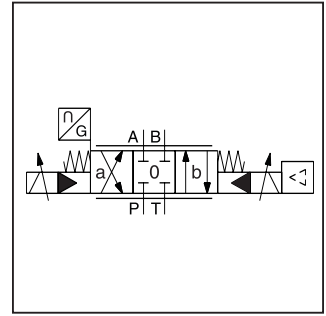

Standard D*1FC

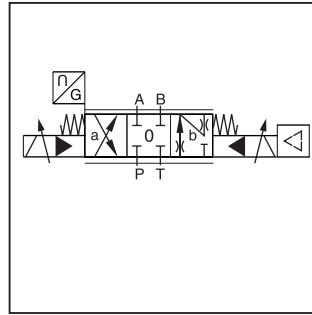

Regeneration D*1FCR

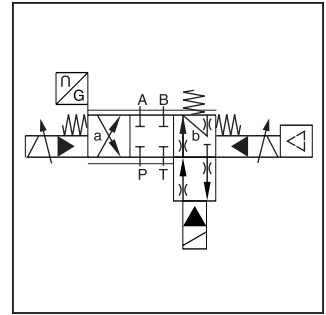

Hybrid D*1FCZ

Further literature about the opportunities of energy savings and more functional details of the integrated regeneration is available on request at Parker HVD Technical Service.

D41FC

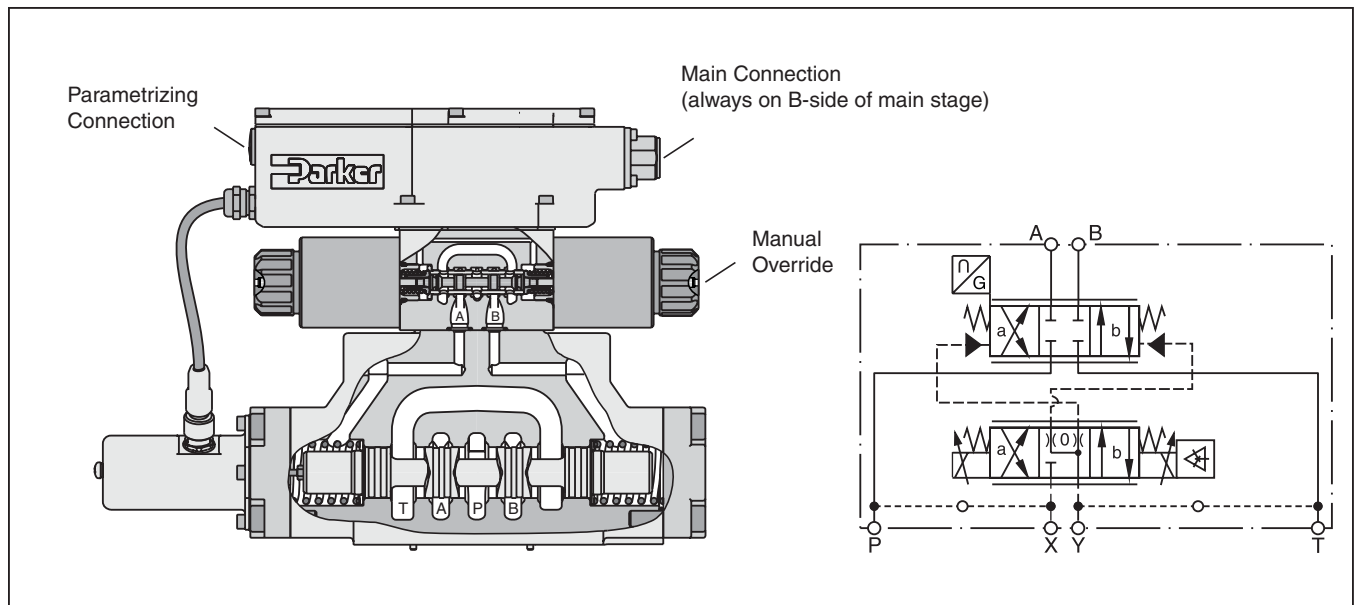

D*1FCR and D*1FCZ

A

Regenerative Valve D*1FCR

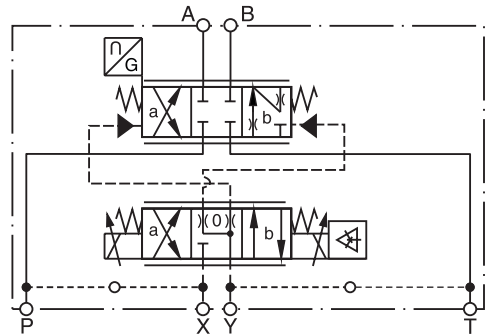
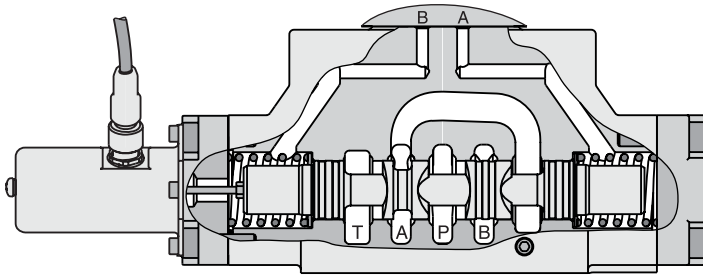

Hybrid Valve D*1FCZ

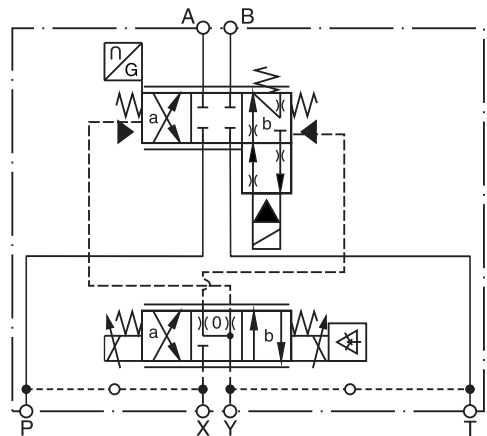
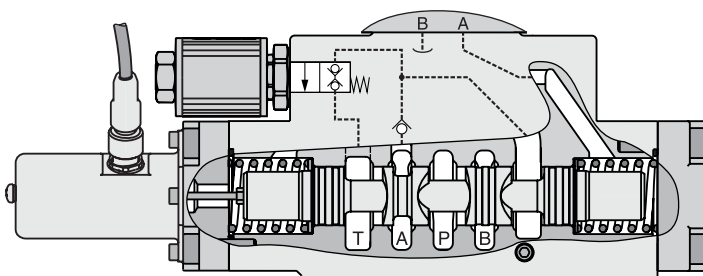

D*1FCR (Regenerative Valve)

Cylinder extending
 (high speed)

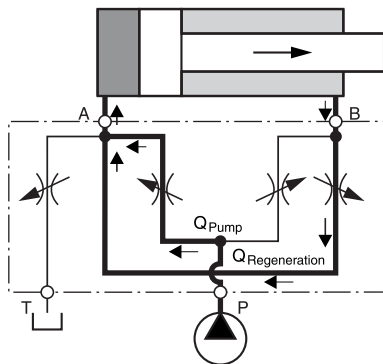

D*1FCZ (Hybrid Valve)

Cylinder extending
 regenerative mode
 (high speed)

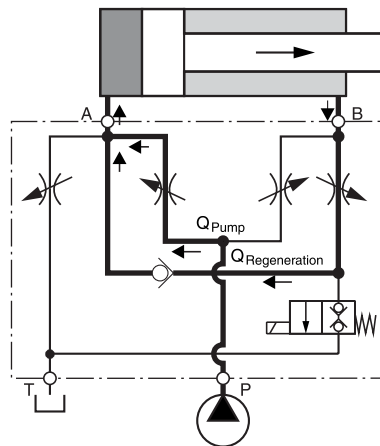

Cylinder extending
 standard mode
 (high force)

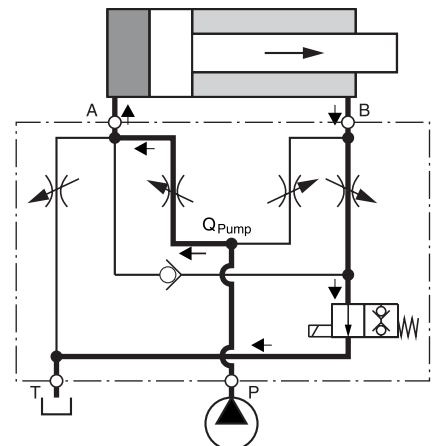

Flow Rate in % of Nominal Flow

Size	Spool	Port					
		A-T	P-A	P-B	B-A (R-Valve)	B-A (Hybrid)	B-T (Hybrid)
D41FCR/Z	31/32	100%	50%	100%	50%	45%	20%
D91FCR/Z	31/32	100%	50%	100%	50%	50%	25%
D111FCR/Z	31/32	100%	50%	100%	50%	50%	20%

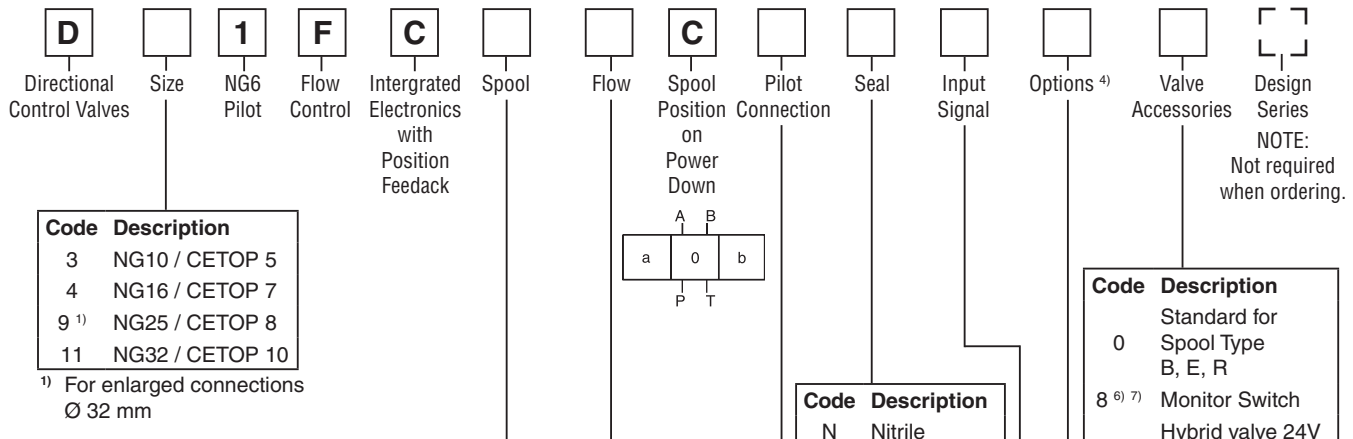

Code	Description
3	NG10 / CETOP 5
4	NG16 / CETOP 7
9 ¹⁾	NG25 / CETOP 8
11	NG32 / CETOP 10

¹⁾ For enlarged connections
 Ø 32 mm

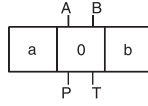

Code	Description
N	Nitrile
V	Fluorocarbon

Code	Description
0	Standard for Spool Type B, E, R
8 ^{6) 7)}	Monitor Switch Hybrid valve 24V normally closed for spool type Z
L ⁵⁾	

⁵⁾ See previous page for regenerative and hybrid spool information. (not available in D31FC)
⁶⁾ Not for D111FCZ*
⁷⁾ Monitor switch for hybrid valves: Code 8 includes options of Code L (24 normally closed).

Standard		NEW: Regenerative Function ²⁾		NEW: Hybrid Function ²⁾	
Code	Spool Type	Code	Spool Type	Code	Spool Type
E01					
E02					
B31	$Q_B = Q_A / 2$ 	R31		Z31	
B32	$Q_B = Q_A / 2$ 	R32		Z32	

Code	Inlet	Drain
1	Internal	External
2	External	External
4	Internal	Internal
5	External	Internal

Code	Signal	Function
B	0...±10V	0...+10V P->B
E	0...±20mA	0...+20mA P->B
K	0...±10V	0...+10V P->A
S	4...20mA	12...20mA P->A

Code	Description
0	6+PE acc. EN175201-804
7	6+PE + enable

⁴⁾ Please order plugs separately. See Accessories.

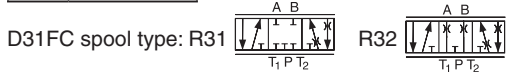

²⁾ For regenerative and hybrid function at D31FC (NG10) please refer to solutions with sandwich and adapter plates: A10-1664 / A10-1665L / H10-1662 / H10-1666L.

Code	Flow LPM (GPM) at Δp 5 Bar (72.5 PSI) per metering edge			
	D31	D41	D91	D111
D	90 (23.8)	—	—	—
E	120 (31.7)	—	—	—
F	—	200 (52.8)	—	—
H	—	—	450 (119.0)	—
L	—	—	—	1000 (264.2)

Bolt Kits:

D31FC	BK385
D41FC	BK320
D91FC	BK360
D111FC	BK386

Weight:

D31FC	9.0 kg (19.8 lbs.)
D41FC	12.5 kg (27.6 lbs.)
D91FC	21.0 kg (46.3 lbs.)
D111FC	68.5 kg (151.0 lbs.)



A

General				
Design	Pilot operated DC valve			
Actuation	Proportional solenoid			
Size	NG10 (CETOP 5) D31	NG16 (CETOP 7) D41	NG25 (CETOP 8) D91	NG32 (CETOP 10) D111
Mounting Interface	DIN 24340 / ISO 4401 / CETOP RP121 / NFPA			
Mounting Position	Unrestricted			
Ambient Temperature	[°C]	-20...+60; (-4°F...+140°F)		
MTTF _D Value	[years]	50		
Vibration Resistance	[g]	10 Sinus 5...200 Hz acc. IEC 68-2-6 30 Random noise 20...20 Hz acc. IEC 68-2-36 15 Shock acc. IEC 68-2-27		
Hydraulic				
Maximum Operating Pressure	Pilot Drain Internal Ports P, A, B, X 350 Bar (5075 PSI); Ports T, Y 210 Bar (3045 PSI) Pilot Drain External Ports P, A, B, T, X 350 Bar (5075 PSI); Port Y 210 Bar (3045 PSI)			
Fluid	Hydraulic oil as per DIN 51524...51535, other on request			
Fluid Temperature	[°C]	-20...+60; (-4°F...+140°F)		
Viscosity				
Permitted	[cSt] / [mm ² /s]	20...380 (93...1761 SSU)		
Recommended	[cSt] / [mm ² /s]	30...80 (139...371 SSU)		
Filtration	ISO 4406 (1999) 18/16/13 (acc. NAS 1638: 7)			
Nominal Flow at Δp= 5 Bar (72.5 PSI) per Control Edge ¹⁾	90/120 LPM (23.8/31.7 GPM)	200 LPM (52.9 GPM)	450 LPM (119.0 GPM)	1000 LPM (264.6 GPM)
Leakage at 100 Bar (1450 PSI)				
Main Stage	[ml/min]	200 (12 cu. in.)	200 (12 cu. in.)	600 (37 cu. in.)
Pilot Stage	[ml/min]	<100 (6.1 cu. in.)		
Pilot Supply Pressure	20 Bar (290 PSI) to 350 Bar (5075 PSI)			
Pilot Flow, Step Response	2.9 LPM (0.8 GPM)	4.1 LPM (1.1 GPM)	6.7 LPM (1.8 GPM)	15.0 LPM (4.0 GPM)
Static / Dynamic				
Step Response at 100% Step ²⁾	[ms]	35	37	66
Hysteresis	[%]	≤ 0.1		
Sensitivity	[%]	≤ 0.5		

¹⁾ Flow rate for different Δp per control edge: $Q_x = Q_{Nom.} \cdot \sqrt{\frac{\Delta p_x}{\Delta p_{Nom.}}}$

²⁾ Measured with load [210 Bar (3045 PSI) pressure drop/two control edges].

Continued on the next page

Electrical		
Duty Ratio	[%]	100 ED; CAUTION: Coil temperature up to 150°C (302°F) possible
Protection Class		IP65 in accordance with EN 60529 (plugged and mounted)
Supply Voltage/Ripple DC	[V]	18...30, ripple < 5% eff., surge free
Current Consumption Maximum	[A]	2.0
Pre-fusing Medium Lag	[A]	2.5
Input Signal		
Code K (B)	Voltage Impedance [V] [kOhm]	+10...0...-10, ripple < 0.01 % eff., surge free, 0...+10V P→A (P→B) 100
Code E	Current Impedance [mA] [Ohm]	20...0...-20, ripple < 0.01 % eff., surge free, 0...+20 mA P→A (P→B) 200
Code S	Current Impedance [mA] [Ohm]	4...12...20, ripple < 0.01 % eff., surge free, 12...20mA P→A < 3.6 mA = enable off, > 3.8 mA = enable on (acc. to NAMUR NE43) 200
Differential Input Maximum		
Code 0/7	[V]	30 for terminal D and E against PE (terminal G)
Code 0	[V]	11 for terminal D and E against 0V (terminal B)
Adjustment Ranges:		
Minimum	[%]	0...50
Maximum	[%]	50...100
Ramp	[s]	0...32.5
Interface		RS-232, parametrizing connection 5 pole
EMC		EN 61000-6-2, EN 61000-6-4
Electrical Connection		6 + PE acc. to EN 175201-804
Wiring Minimum	[mm ²]	7 x 1.0 (AWG16) overall braid shield
Wiring Length Maximum	[m]	50 (164 ft.)
Electrical (Hybrid Option)		
Duty Ratio	[%]	100 ED; CAUTION: Coil temperature up to 150°C (302°F) possible
Protection Class		IP65 in accordance with EN 60529 (plugged and mounted)
Supply Voltage	[V]	24
Tolerance Supply Voltage	[%]	±10
Current Consumption	[A]	1.21
Power Consumption	[W]	29
Solenoid Connection		Connector as per EN 175301-803
Wiring Minimum	[mm ²]	3 x 1.5 recommended
Wiring Length Maximum	[m]	50 (164 ft.) recommended

With electrical connections the protective conductor (PE ↓) must be connected according to the relevant regulations.

D*1FC B/E

A

D31FC

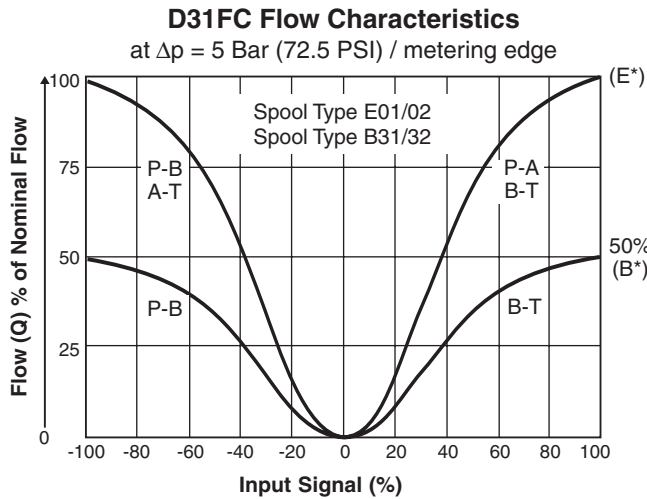

D41FC

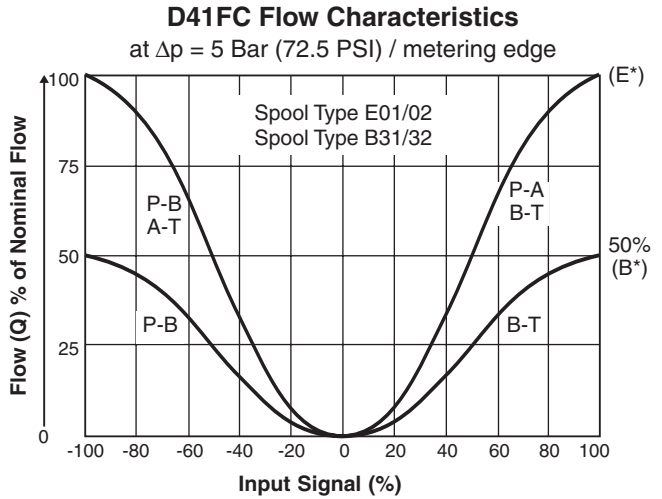

D91FC

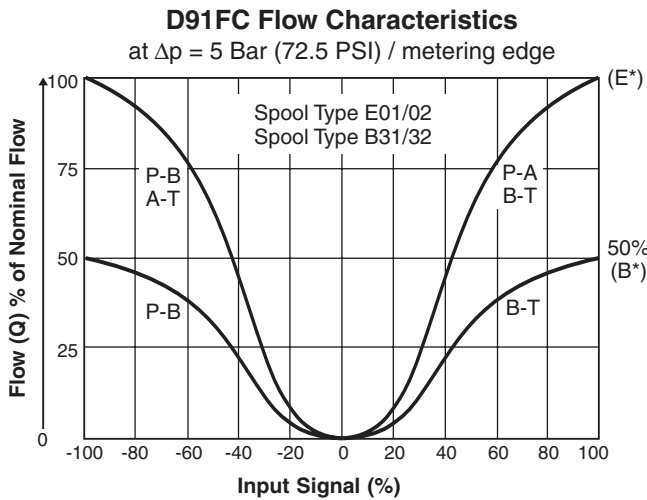

D111FC

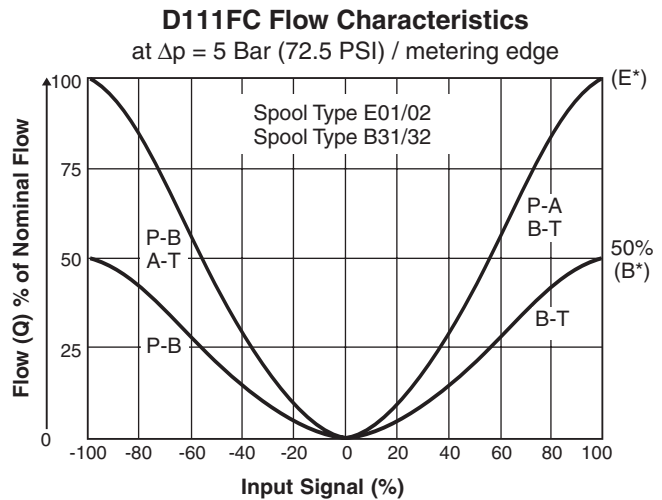

All performance curves measured with HLP46 at 50°C (122°F).

D*1FCR/Z

D31FC

D31FCR Flow Characteristics
 at $\Delta p = 5 \text{ Bar (72.5 PSI)}$ / metering edge

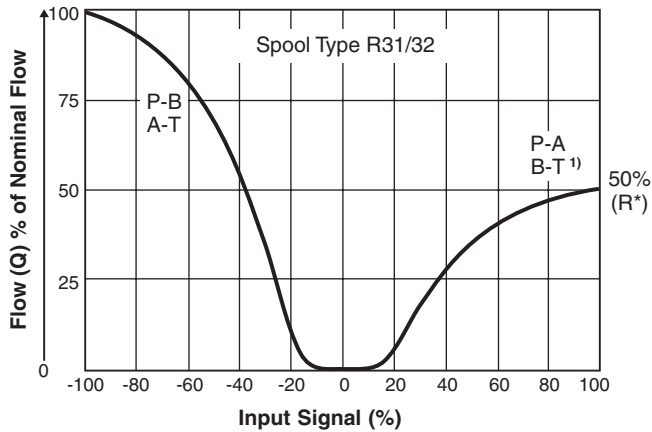

¹⁾ with 2 tank ports

D41FC

D41FCR/Z Flow Characteristics
 at $\Delta p = 5 \text{ Bar (72.5 PSI)}$ / metering edge

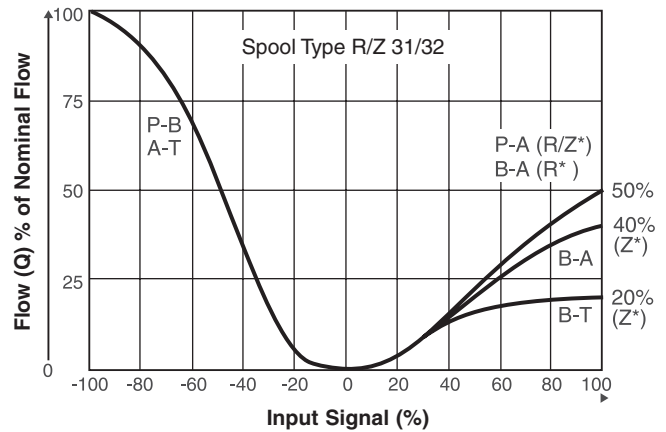

D91FC

D91FCR/Z Flow Characteristics
 at $\Delta p = 5 \text{ Bar (72.5 PSI)}$ / metering edge

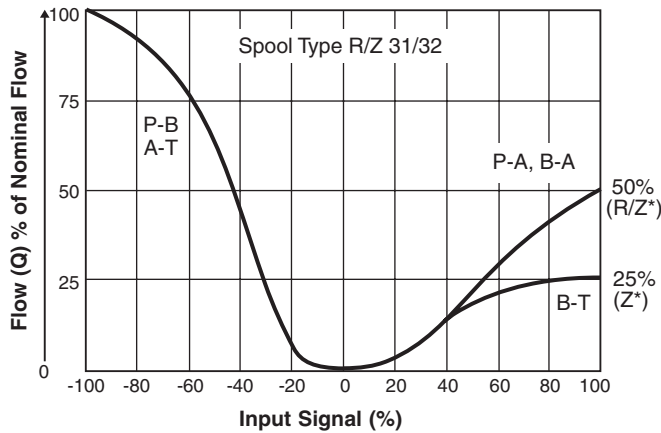

D111FC – Spool Type R/Z on request

All performance curves measured with HLP46 at 50°C (122°F).

Monitor Switch M12x1 Pin Assignment

A

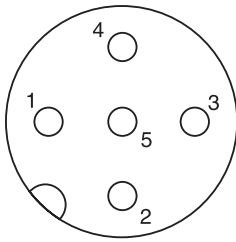

- 1 + Supply 18...42V
- 2 Output B (normally closed)
- 3 0V
- 4 Output A (normally closed)
- 5 Earth ground

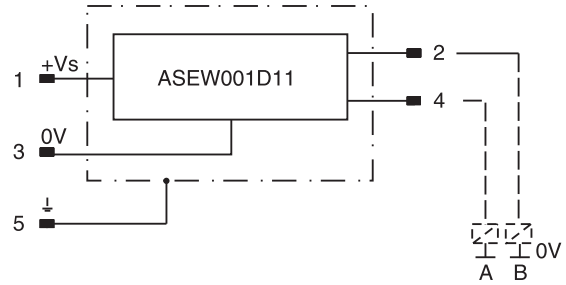

Signal	Output A (pin 4)	Output B (pin 2)
neutral	closed	closed
	open	closed
	closed	open

The neutral position is monitored. The signal changes after less than 10% of the spool stroke.

Electrical Monitor Switch

Protection Class	IP65 in accordance with EN 60529 (plugged and mounted)
Ambient Temperature	[°C] 0...70; (32°F...158°F)
Supply Voltage/Ripple	[V] 18...42, ripple < 10% eff.
Current Consumption without Load	[mA] < 30
Maximum Output Current per Channel, Ohmic	[mA] 400
Minimum Output Load per Channel, Ohmic	[kOhm] 100
Maximum Output Drop at 0.2A	[V] < 1.1
Maximum Output Drop at 0.4A	[V] < 1.6
EMC	EN 61000-6-2, EN61000-6-4
Maximum tol. Ambient Field Strength	[A/m] 1200
Minimum Distance to Next AC solenoid	[m] 0.1
Interface	4+PE acc. IEC 61076-2-101 (M12)
Wiring Minimum	[mm²] 5 x 0.5 (AWG 20) overall braid shield
Wiring Length Maximum	[m] 50 (164 ft.)

Code 0
6 + PE acc. to EN 175201-804

Code 7
6 + PE acc. to EN 175201-804 + enable

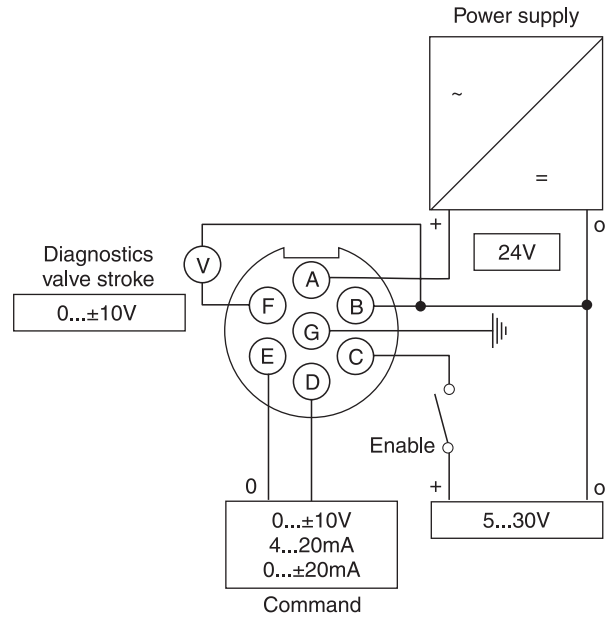
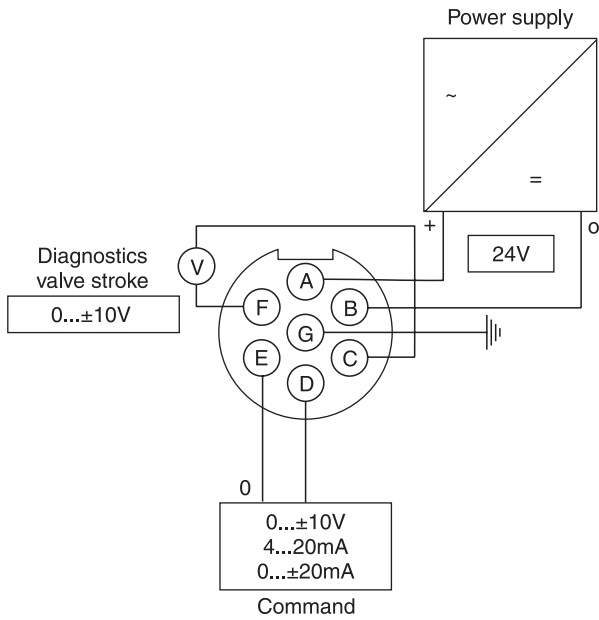

ProPxD Interface Program

A

The ProPxD software allows quick and easy setting of the digital valve electronics. Individual parameters as well as complete settings can be viewed, changed and saved via the comfortable user interface. Parameter sets saved in the non-volatile memory can be loaded to other valves of the same type or printed out for documentation purposes.

Features

- Simple editing of all parameters.
- Storage and loading of optimized parameter adjustments.
- Executable with all Windows® operating systems from Windows® 95 upwards.
- Communication between PC and electronics via serial interface RS-232.

The valve electronics cannot be connected to a PC with a standard USB cable – this can result in damages of PC and/or valve electronics.

Simple to use interface program. Download free of charge www.parker.com/euro_hcd → **Services** → **downloads**

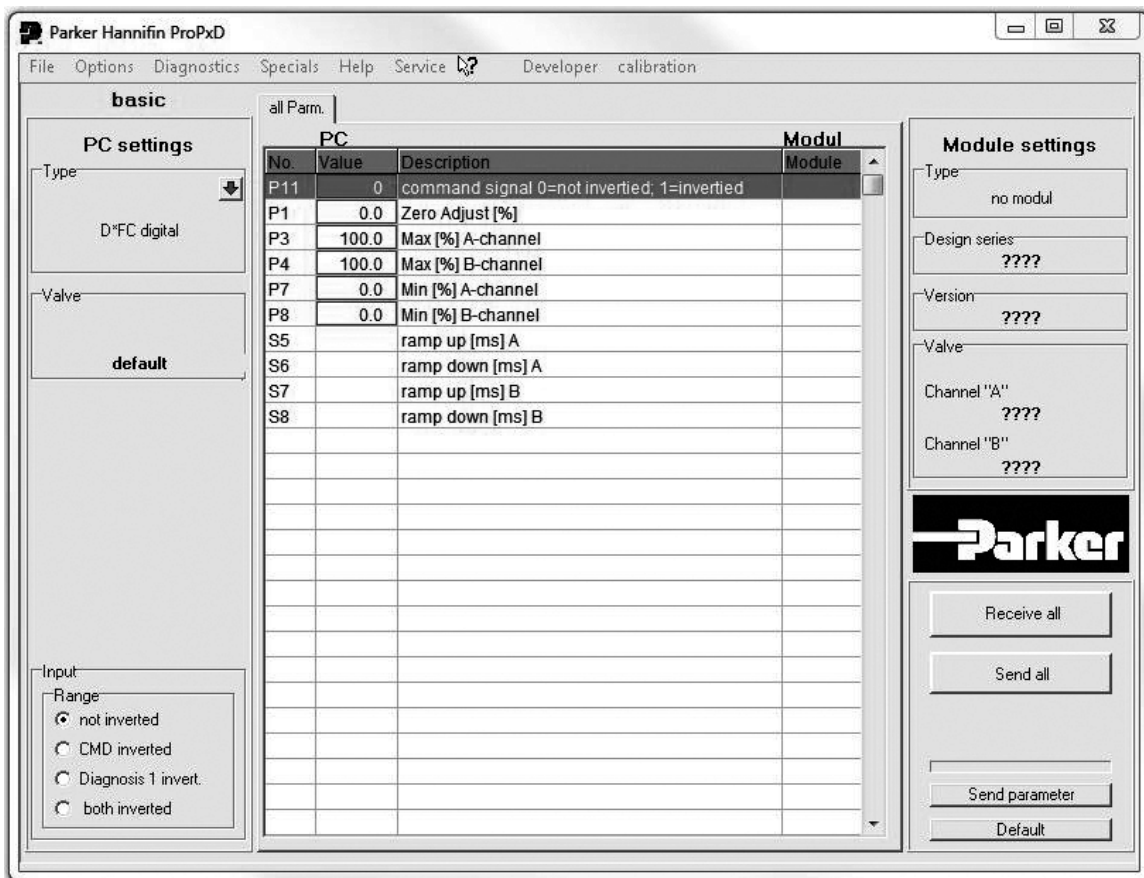

The parametrizing cable may be ordered under item no. 40982923.

Pilot Flow — Pilot Oil Inlet (Supply) and Outlet (Drain)

○ open, ● closed

Pilot oil		B	C
Inlet	Drain		
internal	external	○	●
external	external	●	●
internal	internal	○	○
external	internal	●	○

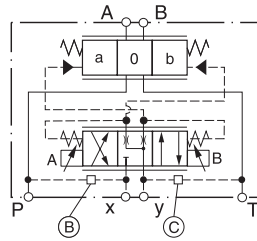

D31FCB/E

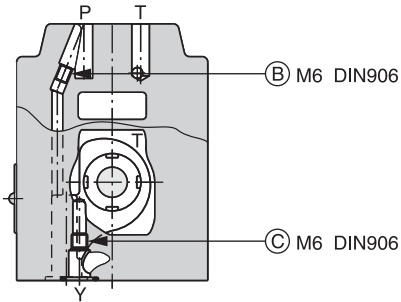

(drawn offset)

D31FCR

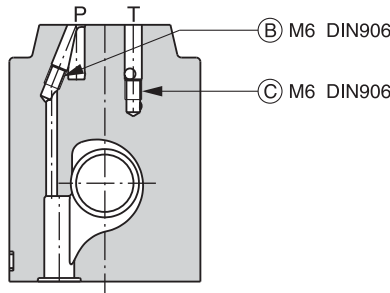

D41FCB/E

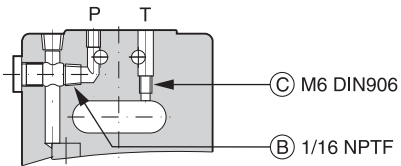

D41FCR

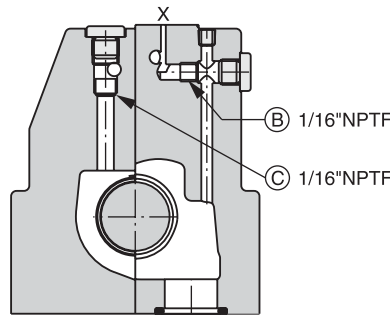

(drawn offset)

D41FCZ

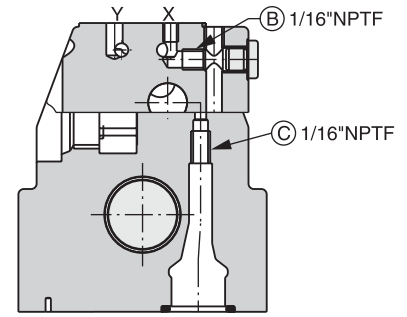

(drawn offset)

D91FCB/E

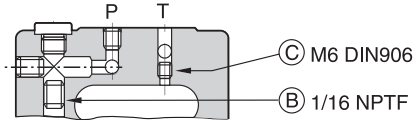

D91FCR

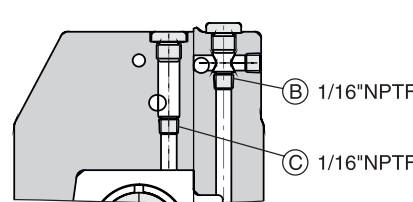

(drawn offset)

D91FCZ

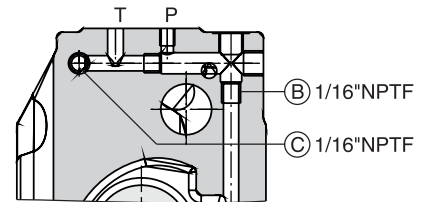

D111FCB/E

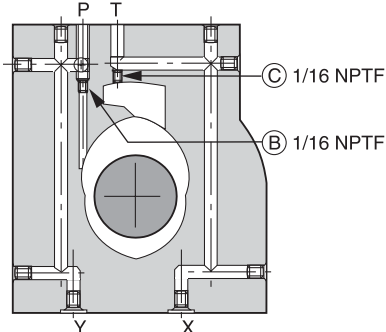

D111FCR

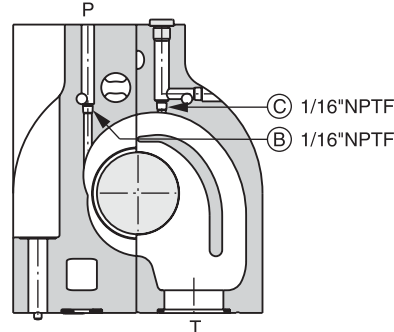

(drawn offset)

D111FCZ

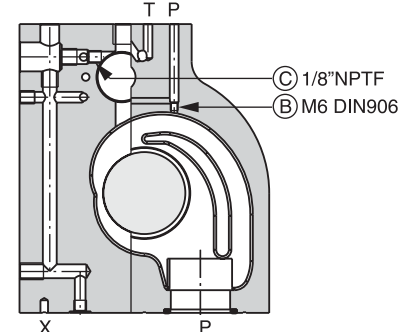

(drawn offset)

D_1FC.indd, ddp



Inch equivalents for millimeter dimensions are shown in (**)



A

D31FC

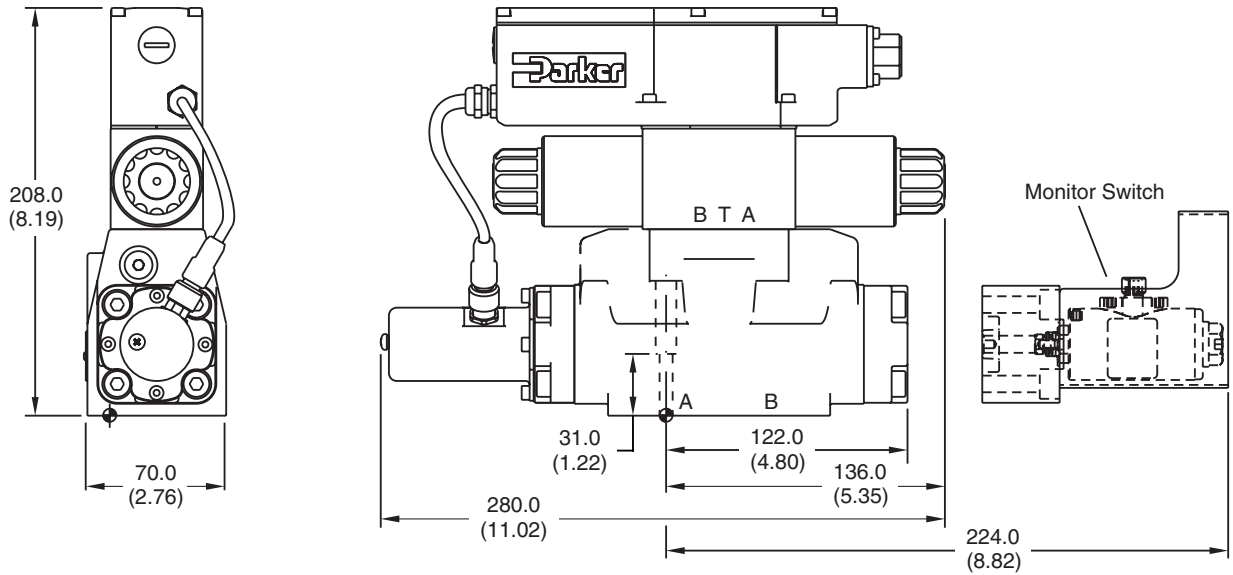

Regenerative and hybrid function with additional plate H10-1666L, H10-1662, A10-1664, A10-1665L.

Surface Finish	Kit			Seal Kit
	BK385	4x M6x40 ISO 4762-12.9	13.2 Nm (9.7 lb.-ft.) ±15 %	Nitrile: SK-D31FC Fluorocarbon: SK-D31FC-V

D41FC

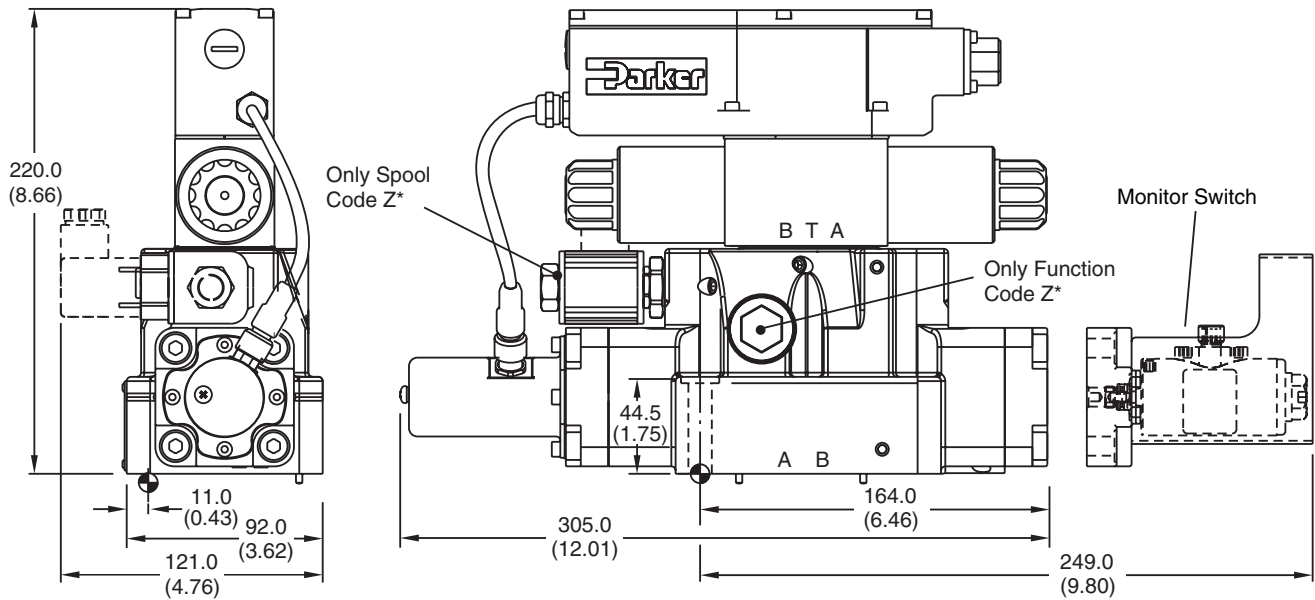

Surface Finish	Kit			Seal Kit
	BK320	2x M6x55 4x M10x60 ISO 4762-12.9	13.2 Nm (9.7 lb.-ft.) 63 Nm (46.5 lb.-ft.) ±15 %	Nitrile: SK-D41FC Fluorocarbon: SK-D41FC-V

Inch equivalents for millimeter dimensions are shown in (**)



A

D91FC

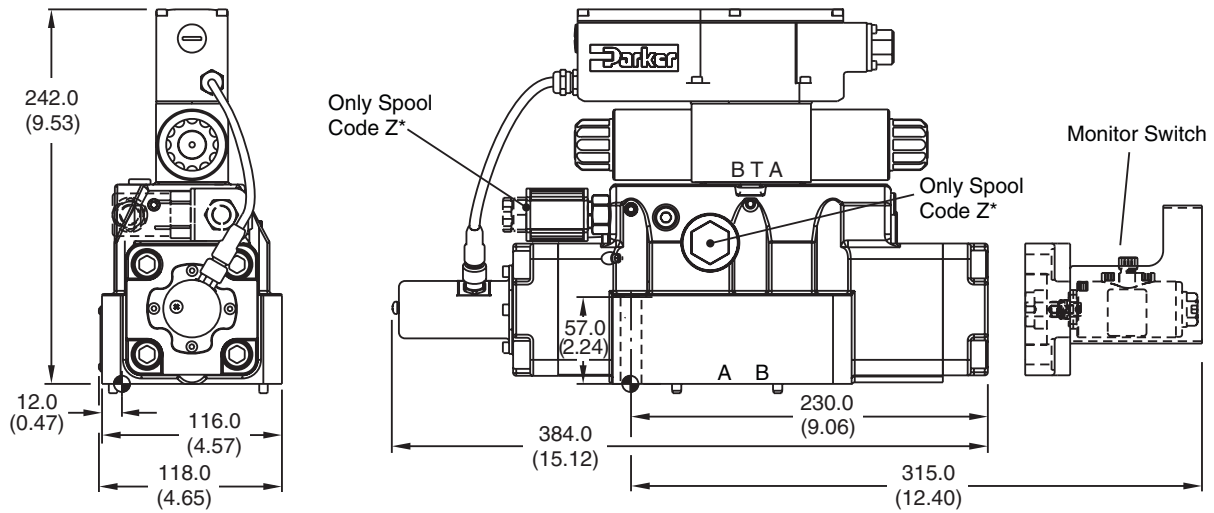

Surface Finish	Kit	ISO 4762-12.9	Torque	Seal Kit
$\sqrt{R_{max}6.3}$ $\square 0.01/100$	BK360	6x M12x75 ISO 4762-12.9	108 Nm (79.7 lb.-ft.) ±15 %	Nitrile: SK-D91FC Fluorocarbon: SK-D91FC-V

D111FC

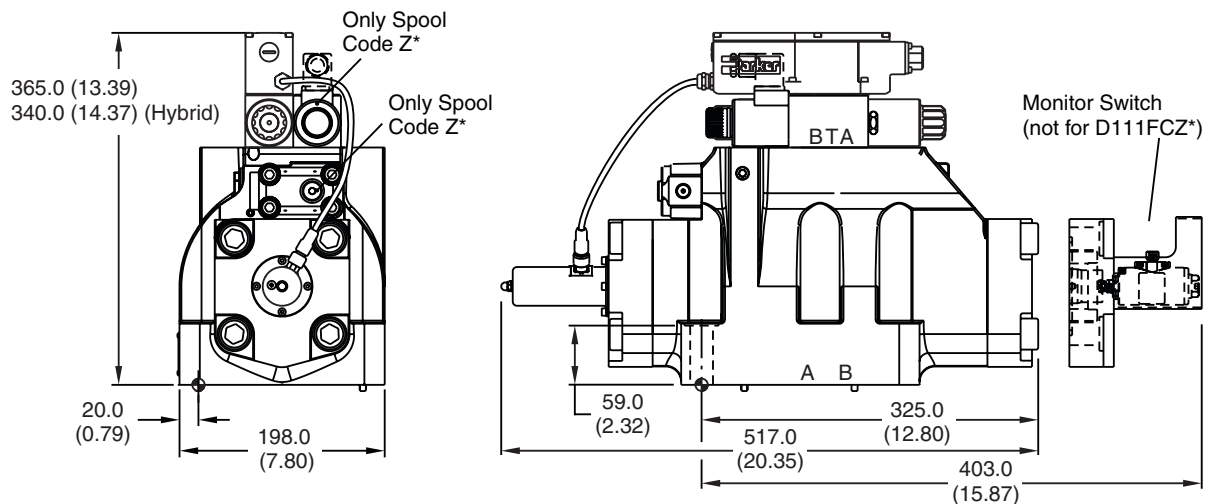

Surface Finish	Kit	ISO 4762-12.9	Torque	Seal Kit
$\sqrt{R_{max}6.3}$ $\square 0.01/100$	BK386	6x M20x90 ISO 4762-12.9	517 Nm (381.3 lb.-ft.) ±15 %	Nitrile: SK-D111FC Fluorocarbon: SK-D111FC-V